

# ASSEMBLY INSTRUCTIONS for MOUNTING STRAIGHTEDGE with EDGEMOUNT CABLE SYSTEM

**COMPONENTS:**

REF.#	QTY.	DESCRIPTION	PART No.
A	1	RIGHT CORNER PLATE ASSEMBLY	A2294
B	1	LEFT CORNER PLATE ASSEMBLY	A2295
C	2	SIDE GUIDE	B1003
D	4	#6 x 1/2" SCREW	X37
E	1	CABLE CLAMP	B9
F	3	KNOB	K22
G	2	WASHER	W42
H	2	#6 x 1" SCREW	X14
J	2	STEDGE STOP	F330

**PRIOR TO ASSEMBLING** - Compare contents of Hardware Bag to list at left to insure complete assembly.

1. Remove tape holding ends of cable and place straightedge in position on Worksurface. Install Knob (F) and Washer (G) on both ends of straightedge. Do not tighten at this time. (See Fig. #1)

2. IF STRAIGHTEDGE IS FULL LENGTH OF WORKSURFACE AND NO SIDE MOTION IS DESIRED: Insert Side Guides (C) under pulley housing cover as shown in Fig. #1. Guides may be bent with fingers to fit Worksurface.

IF STRAIGHTEDGE IS NOT FULL LENGTH OR SIDE GUIDES ARE NOT DESIRED: Side Guides can be eliminated without affecting operation of unit.

3. Position Corner Plates (A) and (B) so cable runs parallel with Worksurface edge. (See Fig. #4). Mark hole locations.

4. Drill 3/32" pilot holes at marked locations.

5. Secure Corner Plates using four #6 x 1/2 Screws (D). (See Fig. #2)

6. Install cable Clamp (E) onto Stud of Left Corner Plate (C). Be sure cable passes between Clamp and Corner Plate. Turn Knob (F) onto Stud. (See Fig. #2 for correct installation). See Fig. #4 for Spring position. Tighten Knob (F) when spring is centered.

7. Position the Stedge Stop (J) on the front edge so the cable is parallel with the Worksurface sides. Mark holes on the Worksurface edge. (See Fig. #3) Repeat this step for both sides.

8. Drill 3/32" pilot holes at marked locations.

9. Insert cable through Stedge Stop and attach to the Worksurface using Screws (H).

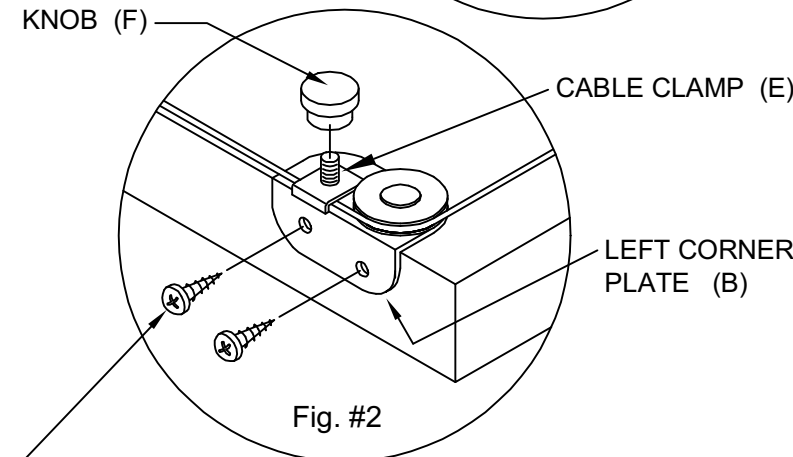
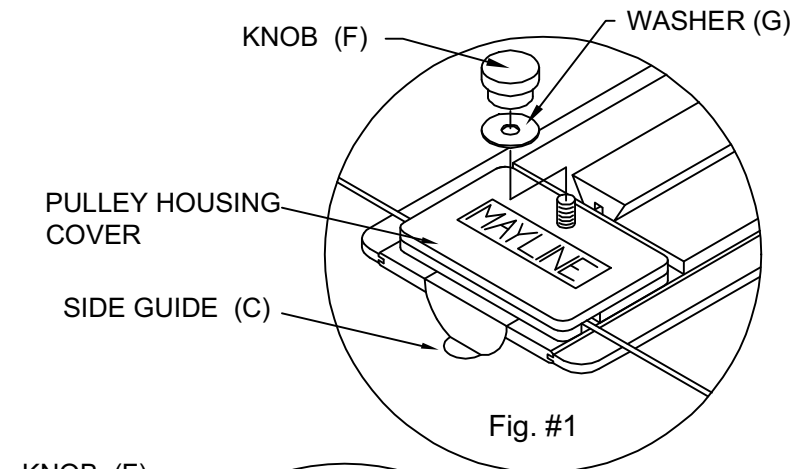

#6 x 1/2" SCREWS (D) **NOTE:** Pre-drilling 3/32" pilot holes is recommended for these screws.

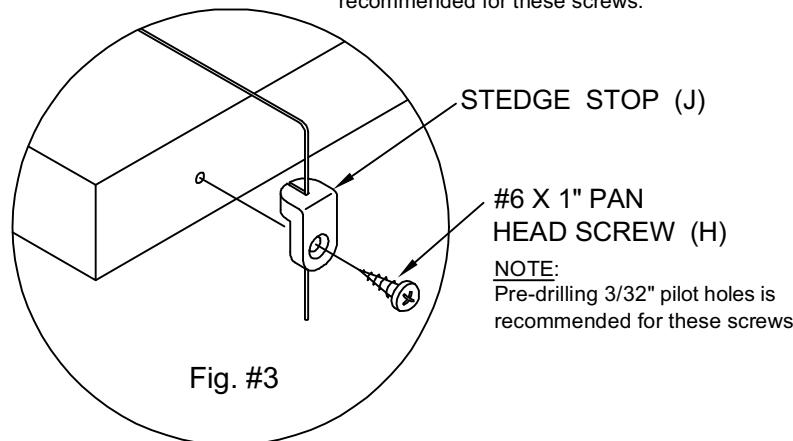

10. Pull cable on RIGHT side of worksurface to remove slack from this portion. Tighten Stedje Stop Screw (H) at this time.

11. Pull cable on LEFT side to remove slack. Do not exceed spring tension (See Fig. #4). Tighten Stedje Stop Screw (H).

12. Excess cable can be trimmed off leaving several inches for future adjustments.

13. Straightedge may be locked in position by tightening Knobs installed in Step #1 on both ends of Straightedge or left loose to allow free movement up or down.

